

CAD FILE:

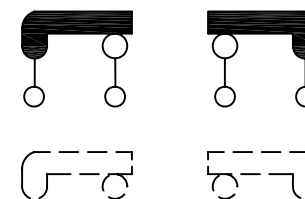

SCHEMATIC

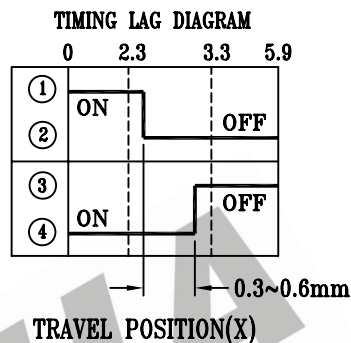
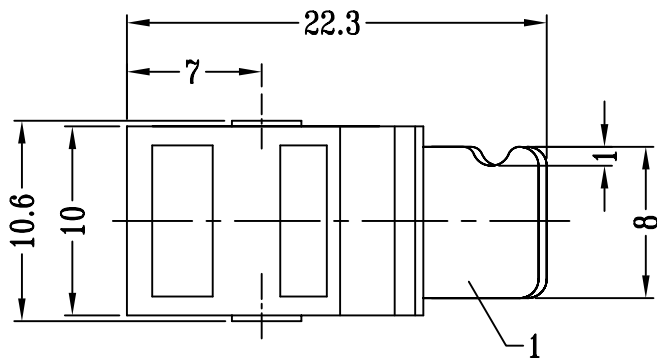
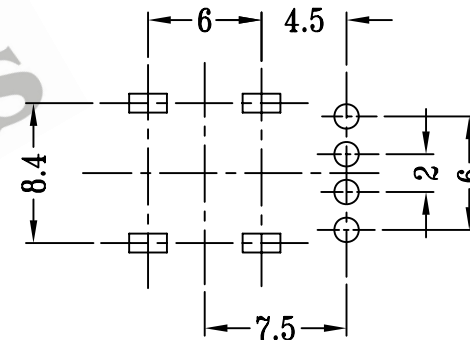
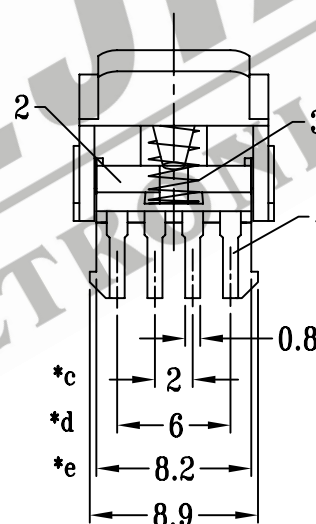
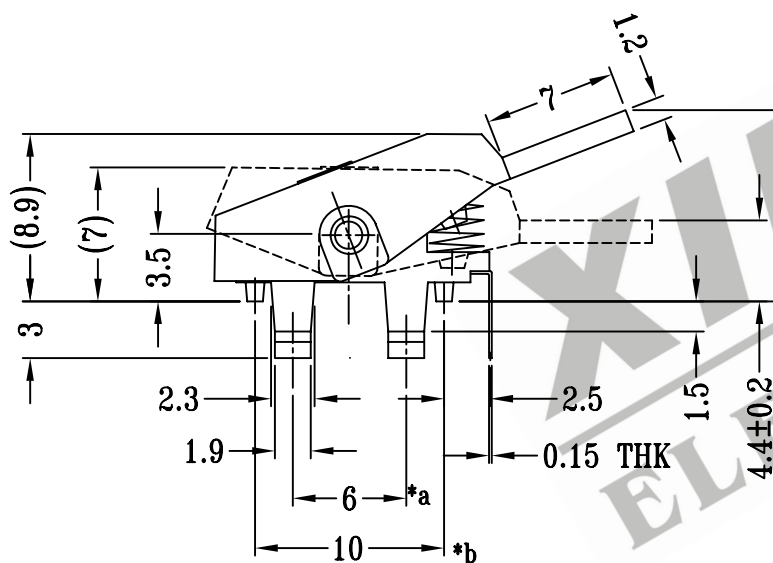

P.C.B LAYOUT

注:带"*"表示关键尺寸(5个)

8					TOLERANCE	SHENZHEN XIEJIA ELECTRONICS CO.,LTD.					
7					UNLESS SPECIFIED						
6					WITHIN: 1.5±0.1mm						
5					OVER : 1.5±0.2mm	ISSUE	DATE	DESCRIPTIONS OF REVISION	APPD.		
4	TERMINAL	Au+Ag CLAD PBS STRIP	1	Au+Ag CLAD	TITLE : HOOK SWITCH			UNIT : mm	DRWG NO.: XJ-DR-HS22L10-00		
3	SPRING	33# SWP	1	TEMPER	MODEL: HS-22L10			SCALE: 5:2	DWN.	ZHOUYU	2005-8-9
2	CASE	PPS	1	BROWN					CHK'D	FANGYING	2005-8-9
1	KNOB	POM	1	IVROY					APPD.	KANGXINAN	2005-8-9
NO.	PARTS	MATERIALS	Q'TY	FINISH	ALL MATERIALS MUST BE COMPLIANT TO ROHS						